

I.D. IMPRINTED

.125 RAISED CHARACTER LOCATE AS SHOWN

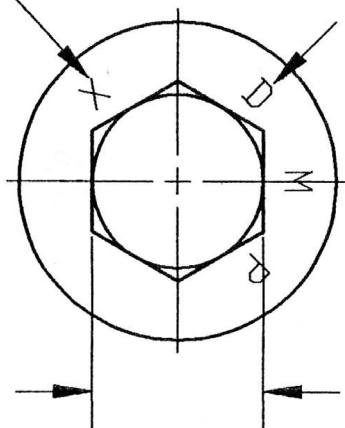

13/16 HEX H.F.
HEX MUST PASS
THRU 15/16 DIA HOLE

ALL DIMENSIONS ARE
REFERENCE AND ARE
IN INCHES, EXCEPT AS
NOTED

Item	Part No.	QTY	Description
1	DMP 321	1	Line post stud
2	SN 7/8	1	7/8 square nut
3	LN 7/8	1	7/8 lock nut
4	SW 7/8	1	7/8 square washer
5	LW 7/8	1	7/8 spring lock washer

DMP

DOWNEY METAL PRODUCTS, INC.

7000 Airways Park Drive, East Syracuse, N.Y. 13057
www.downeymetal.com | (315) 433-1130

PRODUCT NAME

Line Post Stud Assembly

PRODUCT DESCRIPTION

Line post studs. Long shank for wood crossarms. All Studs are Hot Dip Galvanized and Stressed Relieved.

PRODUCT NUMBER

DMP-321